

## TO-220-3L Plastic-Encapsulate Transistors

### FEATURES

- TRANSISTOR (NPN)

### MECHANICAL DATA

- Case style:TO-220-3L molded plastic
- Mounting position:any

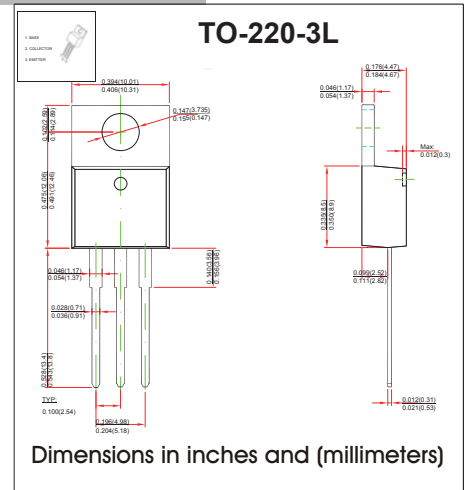

### MAXIMUM RATINGS AND CHARACTERISTICS

@ 25°C Ambient Temperature (unless otherwise noted)

Symbol	Parameter	TIP41	TIP41A	TIP41B	TIP41C	Unit
$V_{CBO}$	Collector-Base Voltage	40	60	80	100	V
$V_{CEO}$	Collector-Emitter Voltage	40	60	80	100	V
$V_{EBO}$	Emitter-Base Voltage	5				V
$I_C$	Collector Current -Continuous	6				A
$P_C$	Collector Power Dissipation	2				W
$T_J$	Junction Temperature	150				°C
$T_{stg}$	Storage Temperature Range	-55~+150				°C

Parameter	Symbol	Test conditions	Min	Max	Unit
Collector-base breakdown voltage	TIP41 TIP41A TIP41B TIP41C	$V_{(BR)CBO}$	$I_C = 1\text{mA}, I_E = 0$	40 60 80 100	V
Collector-emitter breakdown voltage	TIP41 TIP41A TIP41B TIP41C	$V_{CEO(sus)}$	$I_C = 30\text{mA}, I_B = 0$	40 60 80 100	V
Emitter-base breakdown voltage		$V_{(BR)EBO}$	$I_E = 1\text{mA}, I_C = 0$	5	V
Collector cut-off current	TIP41 TIP41A TIP41B TIP41C	$I_{CBO}$	$V_{CB} = 40\text{V}, I_E = 0$ $V_{CB} = 60\text{V}, I_E = 0$ $V_{CB} = 80\text{V}, I_E = 0$ $V_{CB} = 100\text{V}, I_E = 0$	0.4	mA
Collector cut-off current	TIP41/41A TIP41B/41C	$I_{CEO}$	$V_{CE} = 30\text{V}, I_B = 0$ $V_{CE} = 60\text{V}, I_B = 0$	0.7	mA
Emitter cut-off current		$I_{EBO}$	$V_{EB} = 5\text{V}, I_C = 0$	1	mA
DC current gain		$h_{FE(1)}$	$V_{CE} = 4\text{V}, I_C = 0.3\text{A}$	30	
		$h_{FE(2)}$	$V_{CE} = 4\text{V}, I_C = 3\text{A}$	15	75
Collector-emitter saturation voltage		$V_{CE(sat)}$	$I_C = 6\text{A}, I_B = 0.6\text{A}$	1.5	V
Base-emitter voltage		$V_{BE(on)}$	$V_{CE} = 4\text{V}, I_C = 6\text{A}$	2	V
Transition frequency		$f_T$	$V_{CE} = 10\text{V}, I_C = 0.5\text{A}$ $f = 1\text{MHz}$	3	MHz

# RATINGS AND CHARACTERISTIC CURVES

## ■ Typical Characteristics

